

YS: pin 25 of IC304 cut halfway and connected to pin 24 of the same device. By holding this input high the encoder won't switch to external.
 Video out: C354 and C364 are disconnected to reduce the load. C354 can be removed, C364 should be disconnected on the + side the final CVBS signal can be connected to the + pin again for the UHF modulator.

Filter & pal decoder in original state to keep digitizing possible. Improving PAL decoder filter gives aliasing in ADC

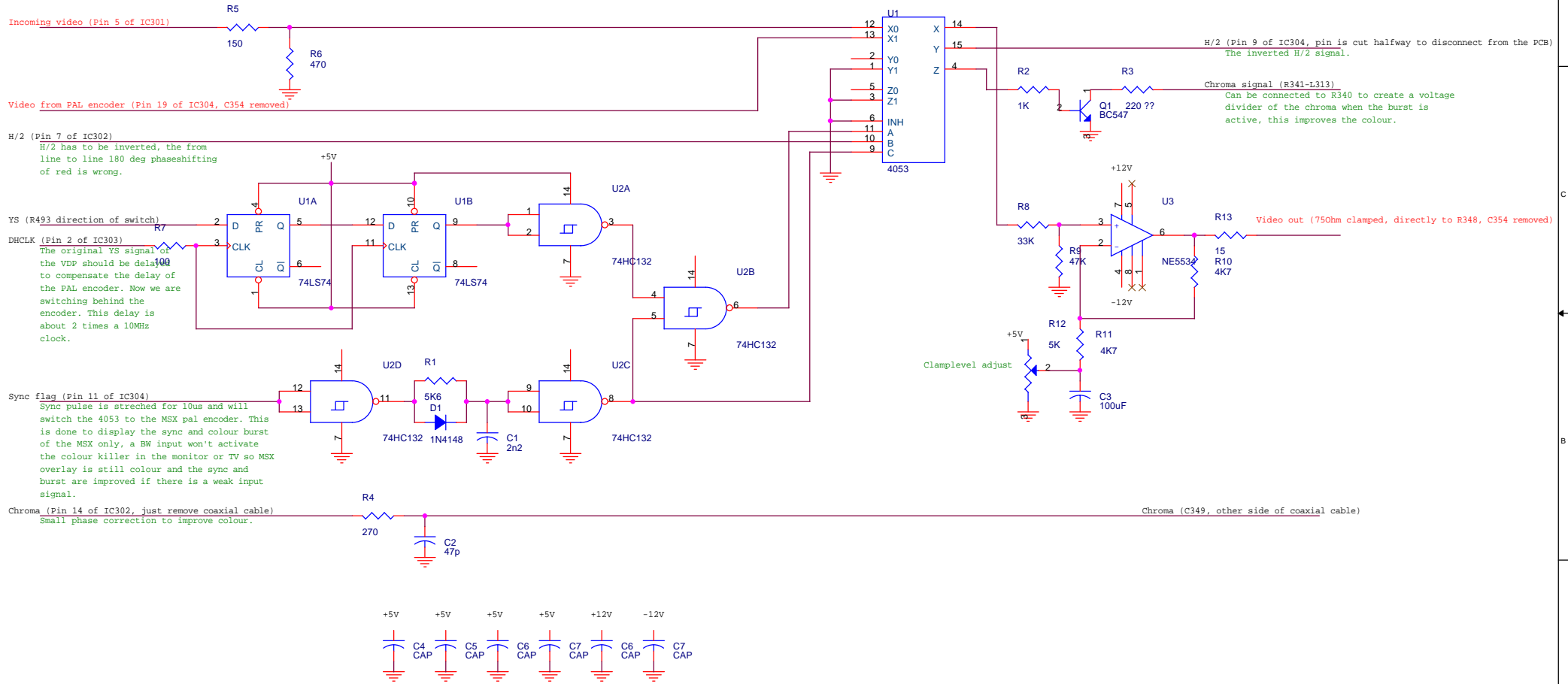

Title		
Dennis Koller		
Size	Document Number	Rev
B	NMS8280 Genlocker	<Rev Code>
Date:	Friday, December 24, 2004	Sheet 1 of 1